

SERVICE INFORMATION

Vol. 1 No. 1

LAND-ROVER PETROL AND DIESEL MODELS



The Rover Company Limited, Solihull,
Warwickshire, England

March, 1972

INDEX

Description	Model	Issue No.	Item No.
Front axle swivel pins	All	1	3
Gearbox	Series IIA only	1	2
Service information (Service News Letters)	All	1	1
White rust on galvanised parts	All	1	4

*Item contains suffix letter change.
Policy items printed in bold type.

Item 1

SUBJECT:

SERVICE INFORMATION (SERVICE NEWS LETTERS) (Policy Item)

REMARKS:

The various methods of presenting information to the franchise holders of the Specialist Car Division Companies, that is, Daimler, Jaguar, Rover and Triumph, have been co-ordinated under the heading of 'Service Information', and in the format shown on this Service Information issue. It must be emphasised that as far as Rover Distributors, Dealers and Fleet Operators are concerned this is merely a change of title from 'Service News Letter' to 'Service Information', but with one important exception—the method of indexing individual Service Information issues. This has been considerably improved, as explained below. To provide ready access to any item, each issue of Service Information will be indexed as follows:

No. 1 will have an index on the first page covering all the items within that particular Service Information issue.

No. 2 will have an index on the first page covering all the items in Service Information issues 1 and 2.

No. 3 will have a separate cumulative index covering all the items in Service Information issues 1, 2 and 3.

No. 4 will have an index applicable only to the items in that Service Information issue.

No. 5 will have an index of the items in Service Information issues 4 and 5.

No. 6 will have a separate cumulative index covering all the items in Service Information issues 1-6 inclusive.

This system will be repeated for a complete volume of 24 Service Information issues.

The Service Information pages are A4 size, slightly larger than the Service News Letters previously issued, and new stiff binders to suit are available from our Parts Department under Part No. 608145 for Land-Rover at a nominal cost of £0.25 each.

Item 2

SUBJECT: **GEARBOX**
MODEL: Land-Rover Series IIA.
MODIFICATION: Introduction of a Series III type gearbox for Series IIA vehicles.

PCMI TRANSPARENCY: The following information will be incorporated in the next available transparency.

PART NUMBER:

Gearbox assembly	1	607125	2½ litre petrol and diesel
Gearbox assembly	1	607127	2.6 litre

REMARKS: This modified version of the Series III all synchromesh gearbox assembly incorporates the existing Series IIA bell housing, primary pinion and clutch withdrawal mechanism which enables the gearbox to be used for Series IIA models. It will be supplied by our Parts Department for all service requirements when present stocks of the Series IIA gearbox assemblies, part numbers 591438, 2½ litre and 591439, 2.6 litre are exhausted. However, components for the Series IIA gearbox will still be available.

To reduce the cost of replacing a complete gearbox, especially in certain overseas territories, the existing Series IIA gearbox may be converted to Series III specification whilst carrying out repairs or a general overhaul.

A list of the minimum parts required to carry out the conversion is shown below. Additional items may of course be required, depending on the general condition of the gearbox.

Gearbox casing assembly	1	606881
Layshaft cluster	1	576686
Mainshaft	1	576725
Inner and outer member, 1st, 2nd and reverse gear	1	576733
Sliding block for synchromesh ball	3	553084
Spring for synchromesh ball	3	503805
Synchromesh ball	3	52459
Synchromesh cone, female	2	591364
1st speed mainshaft gear	1	591362
Bush for 1st speed mainshaft gear	1	576734
Thrust washer for 1st speed mainshaft gear	1	576735
2nd speed mainshaft gear	1	591363
Bolt ($\frac{7}{16}$ in. UNF x $1\frac{1}{2}$ in. long)	} Fixing bearing		1	561601
Washer	} to layshaft		1	576907
Bearing for layshaft, rear	1	576206
Bearing housing for mainshaft, rear	1	576836
Shaft for reverse gear	1	591527
Reverse gear assembly	1	576707
Spring pin for reverse gear shaft	1	591519
Selector fork, 1st and 2nd speed	1	576703
Shaft assembly for fork 1st and 2nd speed	1	576727
Selector fork, reverse	1	576704
Shaft for fork, reverse	1	576729

This list is applicable to both 4 and 6 cylinder models.

Item 3

SUBJECT: **FRONT AXLE SWIVEL PINS**

MODEL: All Land-Rover.

MODIFICATION: Introduction of identification markings on the nut fixing steering lever to swivel pin housing, also amendment to the torque load required for tightening the nuts.

PART NUMBER: Nut, ($\frac{7}{16}$ in. BSF), fixing steering lever to swivel pin housing .. 8 594104

LITERATURE AFFECTED: Land-Rover Workshop Manual Series II and IIA, part two, English, Part No. 606408, Operation F-10, Page 29-F.
 Land-Rover Service News Letter Vol. 3 No. 31, item 166.

REMARKS:

To provide positive identification of the fixing nut Part No. 594104 introduced by News Letter Vol. 3 No. 31, item 166, the latest version of the nut is provided with two grooves 1,0 mm (0.040 in.) wide and 1,0 mm (0.040 in.) deep along the centre line of the nut.

Also note that the torque load figures for tightening these nuts should be 7,0 kgf m (50 lbf ft) and not 4,8 kgf m (35 lbf ft), as previously stated.

Please amend your copies of the literature affected to incorporate the above information.

Item 4**SUBJECT:****WHITE RUST ON GALVANISED PARTS****MODEL:**

All Land-Rover.

REMARKS:

The presence of 'white rust' on galvanised parts has been raised recently by some of our Distributors and Dealers.

Normally 'white rust' does not occur on these parts when freely exposed. Even in cases where a deposit or stain is evident the original surface is usually restored by normal usage and exposure to the elements.

However, for showroom purposes, or where a customer draws attention to this condition, the following cleaning procedure can be carried out: Add to 4,5 litres (1 gallon) of warm water 112 ml (3-4 fluid ozs or half a cup) of 'Teepol' and 113 gms (4 ozs by weight) of Soda Ash. Alternatively, if Soda Ash is not readily available, 170 gms (6 ozs) of domestic washing soda crystals may be used.

Scrub the affected galvanised parts with the liquid using a nylon hand scourer, a metallic type should not be used.

Finally rinse with clean water and dry.

SERVICE INFORMATION

Vol. 1 No. 2

LAND-ROVER PETROL AND DIESEL MODELS



The Rover Company Limited, Solihull,
Warwickshire, England

April, 1972

INDEX Vol. Nos. 1 and 2.

Description	Model	Issue No.	Item No.
Brake and clutch fluid	All	2	5
Engines and gearboxes	All	2	6
Gearbox	Series IIA only	1	2
Leycare sequenced service operations	All	2	8A
Rear axle	109 Bonneted Control	2	7
Service information	All	1	1
Vehicles transported with wet charged batteries fitted	All	2	8
White rust on galvanised parts	All	1	4

*Item containing suffix letter change.
Policy items are printed in bold type.

Item 5

SUBJECT: BRAKE AND CLUTCH FLUID (Policy Item)

MODELS: All Land-Rover.

MODIFICATION: Change to 'Unipart' range of brake and clutch fluid.

PCMI

TRANSPARENCY: The information detailed in this item will be incorporated in the next available transparency.

LITERATURE AFFECTED:

Land-Rover Parts Catalogue, Series IIA, Part No. 608024, Page 08-43.

Land-Rover Parts Catalogue Supplement, Series III 608049.

Land-Rover Workshop Manual, Series II and IIA, Part 2 English, Part No. 606408, Section 'X', page 2X.

Repair Operations Manual, Series III, Part No. 607314, Division 09, page 09-3.

PART NUMBERS: 'Unipart' 410 (Crimson) Specification, current SAE J.1703

8oz	1 GBF 201
16 oz	1 GBF 202
32 oz	1 GBF 203
1 Gall Tin	1 GBF 204
5 Gall Drum	1 GBF 205

REMARKS: 'Unipart' 410 brake and clutch fluid is suitable for vehicles fitted with drum brakes. It is miscible with the previous type and can be safely added when servicing brakes and clutch hydraulic systems on the above models without draining the system.

NOTE 1: 'Unipart' 550 which is specifically formulated for disc brakes may be used to top up Unipart 410, or as an alternative, but the reverse is not permissible.

NOTE 2: Earlier stocks of Unipart 410 may be either colourless or yellow. All future supplies will be Crimson.

CAUTION: Re-seal tins, especially larger ones, immediately after use. Unsealed fluids will absorb moisture resulting in subsequent loss of braking efficiency.



2RC 127

Fig. 1 'Unipart' 410 brake and clutch fluid

Item 6

SUBJECT: ENGINES AND GEARBOXES

MODELS: All Land-Rover.

REMARKS: To assist Distributors and Dealers to place orders for engines and gearboxes, the chart below gives details of all Land-Rover engines and gearboxes currently available from our Parts Department.

ENGINES

Part No. New	Part No. Rebuilt	Model	Remarks
4-cylinder petrol			
241703	245585	1954	
269216	269217	1955-58	
531746	524139	Series II 2½ litre	
605567	600975	Series IIA 2½ litre	Engine suffix to J
605567	605568	7:1 compression ratio	Engine suffix K
606315	607309	Series IIA 2½ litre	Vehicle suffix G onwards
		8:1 Compression ratio	Engines numbered 24100001A onwards
607340	607341	Series III 2½ litre	7:1 compression ratio
607308	607309	Series III 2½ litre	8:1 compression ratio
606315	606316	Series IIA 2½ litre	109 One Ton 8:1 compression ratio
605926	—	Series IIA 88	7:1 compression ratio
		2½ litre USA	Vehicle suffix D only
606140	—	Series IIA 88	7:1 compression ratio
		2½ litre USA	Vehicle suffix F onwards
606997	—	Series IIA 88	8:1 compression ratio
		2½ litre USA	Engine suffix A
			Engines numbered 30700001A onwards
607246	—	Series IIA 88	8:1 compression ratio
		2½ litre USA	Engine suffix B onwards
608204	—	Series III 88	8:1 compression ratio
		2½ litre USA	Engine suffix A
			Engines numbered 25600001A onwards

Bonneted control

Part No. New	Part No. Rebuilt	Model	Remarks
4-cylinder petrol continued			
605567	605568	Series IIA 2½ litre	} Forward control
605569	605570	Series IIB 2¼ litre	
6-cylinder petrol			
605103	—	Series IIA 2.6 litre	} Bonneted control
605104	605861	Series IIA 2.6 litre	
607342	607343	Series III 2.6 litre	
607312	607313	Series III 2.6 litre	
542468	542469	Series IIA 2.6 litre	7:1 compression ratio
601917	601919	Series IIA and Series IIB 2.6 litre	7.8:1 compression ratio
			109 Engine suffix A
			109 Engine suffix B onwards and all 110
} Forward control			
4-cylinder diesel			
247796	276067	Series II 2 litre	1957-61
556831	600978	Series IIA 2¼ litre	Engine suffix A to J
605654	605655	Series IIA 2¼ litre	Engine suffix K onwards
607310	607311	Series III 2¼ litre	} Bonneted control
534085	600724	Series IIA 2¼ litre	
606082	606985	Series IIA 2¼ litre	With Lucas 2 AC Generator Engine suffix A to J
565036	606730	Series IIA 2¼ litre	With Lucas 11 AC Generator Engine suffix K onwards
605727	605728	Series IIA 2¼ litre	With Prestolite Generator Engine suffix A to J
554615	601758	Series IIB 2¼ litre	With Prestolite Generator Engine suffix K onwards
605656	605657	Series IIB 2¼ litre	110 Engine suffix A
			110 Engine suffix B onwards
} Forward control			
} Bonneted control optional			

GEARBOXES

Part No. New	Part No. Rebuilt	Model	Remarks
For use with 4-cylinder petrol and diesel engines			
240168	522776	1954	} Bonneted control
248361	522778	1955-58	
591438	522780	1958-61	
591438	535880	Series IIA	
591438	600917	Series IIA	
607125	607126	Series IIA	
591440	—	Series IIA	
607908	—	Series IIA	Optional with sealed clutch withdrawal unit
576730	607911	Series III	109 One Ton
553162	600918	Series IIA	109
553499	601756	Series IIB	110 suffix A
565014	606208	Series IIB	110 suffix B onwards
576621	—	Series IIB	Optional 110 with sealed clutch withdrawal unit
} Forward control			

GEARBOXES continued

Part No. New	Part No. Rebuilt	Model	Remarks	
For use with 6-cylinder petrol engines				
591439	605911	Series IIA	Gearbox suffix E	} Bonneted control
607127	607128	Series IIA	Series III type all synchromesh gearbox adapted for use on Series IIA models	
591441	—	Series IIA	Optional with sealed clutch withdrawal unit	
607909	—	Series IIA	109 One Ton	
576761	607912	Series III		} Forward control
553163	600919	Series IIA	109	
553501	601757	Series IIB	110 suffix A	
565010	606209	Series IIB	110 suffix B onwards	
576622	—	Series IIB	Optional 110 with sealed clutch withdrawal unit	

Item 7

SUBJECT: REAR AXLE

MODELS: Land-Rover 109 bonneted control models for certain territories in the Export market and Station Wagons only in U.K.

LITERATURE AFFECTED: Land-Rover Series III Parts Catalogue Supplement, No. 608049.

PART NUMBER: Rear axle complete assembly 1 576764

REMARKS: In Land-Rover Service News Letter, Vol. 3, No. 21a, the commencing number of the Salisbury manufactured rear axle was given as 91100001A. This is incorrect, the axles are actually numbered in the range commencing H71/43 onwards.
Distributors and Dealers are requested to amend their records accordingly.

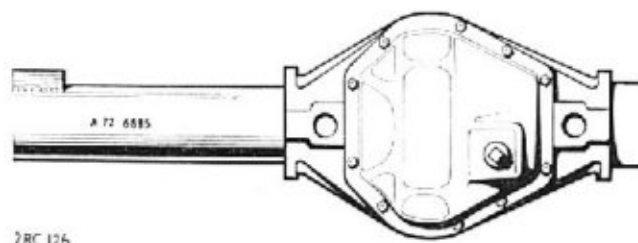

Fig. 2. Location of 'Salisbury' rear axle number

Item 8

SUBJECT: VEHICLES TRANSPORTED WITH WET CHARGED BATTERIES FITTED

MODELS: All Land-Rover.

PARTNUMBERS:

Battery, Exide 6XMM9R or Lucas CA9,	1	567883
Battery, Lucas CA11/9	1	567886
Battery, Exide 6TMZ15L	1	575474

REMARKS:**To overseas distributors as applicable**

To ensure satisfactory life and performance of vehicles delivered to hot climates fitted with wet charged batteries, it will be necessary to correct the strength of the electrolyte as soon as the vehicle arrives.

The following procedure is recommended:

1. Top up with distilled water to correct level.
2. Fully charge the battery at one tenth of the rated capacity (e.g. 60 ampere hours rating —6 amps charge). Check the specific gravity at one hourly intervals and continue to charge until three consecutive readings are consistent.
3. Remove a quantity of electrolyte from each cell, the amount depending on the type of battery used, as follows:-

Exide 6XMM9R	
or Lucas CA9	80 cc
Lucas CA11/9	90 cc
Exide 6TMZ15L	130 cc
4. Top up each cell with the equivalent amount of distilled water.
5. Charge the battery for at least one hour and check for a specific gravity reading of 1.250.

CAUTION. It is important that this method of electrolyte correction is strictly adhered to. It will not prove satisfactory to tip out a quantity of electrolyte and top up with the approved mixture currently used for dry charged batteries. This would result in a high acid content due to residue in the plates and also contamination of the plates by sediment during tipping of the battery.

Item 8A

SUBJECT: LEYCARE SEQUENCED SERVICE OPERATIONS

MODELS: All Land-Rover.

The Repair times for the sequenced service operations, as detailed in the Leycare Section of the Policies and Procedures Manual, Part No. AKD 8000, are as shown in the pink pages of the current Repair Times Schedule, Part No. 606310.

The only exceptions are the pre-delivery times which have been increased because we are now including time for de-waxing and polishing the car, etc.

For your guidance, the charts covering the P.D.I. Free Service and Maintenance Schedules, based on Passport to Service, are reproduced overleaf in full.

LAND-ROVER 88 AND 109 4-CYLINDER PETROL AND DIESEL

Operation No.	Maintenance attention every		Time allowed	
			Petrol	Diesel
	Kilometres	Miles	Hours	Hours
10.10.01	Pre-delivery inspection		3.0	3.0
10.10.03	†1.500	†1,000	3.5	5.2
10.10.06	5.000	3,000	1.7	1.7
10.10.12	10.000	6,000	4.2	3.5
10.10.24	20.000	12,000	5.2	6.7
10.10.48	40.000	24,000	5.4	7.2
10.10.96	80.000	48,000	6.0	7.8

LAND-ROVER 109 6-CYLINDER PETROL

Operation No.	Maintenance attention every		Time allowed
	Kilometres	Miles	Hours
10.10.01	Pre-delivery inspection		3.0
10.10.03	†1.500	†1,000	3.4
10.10.06	5.000	3,000	1.7
10.10.12	10.000	6,000	4.1
10.10.24	20.000	12,000	5.5
10.10.48	40.000	24,000	5.8
10.10.96	80.000	48,000	6.6

†Free Service

70.25.16 Replace brake seals and hoses:

88 models 9.2 hours.

109 models 11.7 hours.

109 models with hydraulic servo 12.9 hours.

70.25.17 Change brake fluid:

All models 1.2 hours.

SERVICE INFORMATION

Vol. 1 No. 3

LAND-ROVER PETROL AND DIESEL MODELS



The Rover Company Limited, Solihull,
Warwickshire, England

May 1972

Item 8B

SUBJECT: SERVICE POLICIES AND PROCEDURES MANUAL U.K. MARKET ONLY
(Policy Item)

MODELS: All Land-Rover.

REMARKS: All Rover Distributors and Dealers are now in possession of the Service Policies and Procedures Manual, Part No. AKD 8000 and will have gathered from reading the Manual that there are a number of new forms introduced which have not previously been used by the Rover Company. The Product Defect Report Form and Service Action Instruction Form are two examples.

We can advise that all the new and revised paperwork in connection with the Service Policies and Procedures Manual will be available for use from the 1st May 1972. Distributors and Dealers should introduce these systems progressively during the month of May 1972. With effect from the 1st June 1972, you are required to conform exactly to the instructions laid down in the Service Policies and Procedures Manual which supersede previous policies and procedures. Any forms submitted to the Factory after the above date, which are not in accordance with these systems, will be rejected.

For your convenience, we list all the new forms together with an indication of their use and from where they can be obtained.

1. Pre-delivery Inspection Form AKD 8001—will be incorporated in Land-Rover literature packs from the 28th April onwards.

2. Product Defect Report Form AKD 8002. Used to speed up vital quality information to the Factory. Obtainable in packs of 10, free of charge, from Technical Service Department, Solihull.

3. Maintenance Schedule Check List AKD 8009—Land-Rover—obtainable from our Parts Department, Cardiff, in pads of 100 sheets, at 10p nett.

This Check List ensures that servicing operations are carried out in a logical sequence. It also includes the essential data, together with a tear-off stores requisition portion.

4. Road and Dynamometer Test Procedure Pads AKD 8013. These are in pads of 100 sheets and can be obtained from our Parts Department, Cardiff, at 10p nett. They should be used in conjunction with Maintenance Schedule Check Lists.

5. Service Reminder Label AKD 8015—available from our Parts Department, Cardiff, in sets of 50 at 10p nett. On completion of the service, the self-adhesive Reminder Label should be attached to the lower part of the 'A' post where it can easily be seen by the driver.

6. Customer Quality Card AKD 8018. These cards are included in the Owner's literature pack on a random basis and invite the customer to comment on the condition of his new car.

7. Transient warranty Card AKD 8020. This card will be incorporated in Land-Rover literature packs with effect from 28th April 1972. The card is for the use of those customers who find it necessary to have warranty work undertaken by a Distributor or Dealer other than the vendor.

8. Warranty Claim Batch Submission Note AKD 8021. All warranty claims must be accompanied by a Batch Submission Note—stocks available on request to the Technical Service Department, Solihull.

9. 1,000 Miles Free Service Voucher AKD 8024. This Free Service Voucher will be incorporated in the Land-Rover literature pack, with effect from 28th April 1972. The card may be used by an owner when it becomes necessary for the 1,000 miles Free Service to be carried out by a Distributor or Dealer other than the vendor.

10. Automatic Gearbox Test Data Form AKD 8026. These forms are in pads of 50, obtainable free of charge from the Technical Service Department, Solihull, and must be completed before seeking advice or guidance on any problem pertaining to the type 35 automatic gearbox unit.

11. Service Action Instruction Sheet AKD 8028. These instructions are issued only in exceptional circumstances and immediate action must be taken to implement the instructions given.

12. Service Action Acknowledgement Form AKD 8031. This is a prepaid-envelope type form addressed to the Principal or Managing Director which must be signed and returned immediately to the Factory to acknowledge receipt of the Service Action Instruction.

13. Technical Literature Catalogue AKD 8033. Contains details of all literature available from the Companies in the Specialist Car Division. This publication will be issued every 3 months, on a free of charge basis, to all on our service mailing list.

14. Exceptional Claim Authorisation AKD 8034—must be used when making any exceptional claim. Copies are available free of charge from the Technical Service Department, Solihull.

15. Binder, grey, Service Information
608145—Land-Rover

16. Binder, grey, Distributors' News Letters
608147—Land-Rover

} Copies of these Binders can be obtained from our Parts Department, Cardiff, at a special nett price of £0.25 each

Items numbered 1, 2, 4, 7, 8, 13 and 14 are applicable to all members of the Specialist Car Division, i.e. Daimler, Jaguar, Rover and Triumph and can be obtained from any one of these Companies. The remainder of the forms shown above are peculiar to Rover and can only be obtained from Rover sources.

It should be noted that forms which are peculiar to a Company, e.g. Service Reminder Labels, which apply to Daimler, Jaguar, Rover and Triumph individually, must be obtained from the Company concerned. Orders for Triumph material, for instance, will not be accepted by Rover or Jaguar and vice versa.

Item 9

SUBJECT: **STEERING COLUMN LOCK LUBRICATION (Policy Item)**

MODEL: Series III Land-Rover.

REMARKS: The locking device used in the above steering lock assembly **must not** be lubricated with oil. This practice can lead to the clogging and jamming of the individual wards inside the locking device barrel rendering it inoperative.

The internal bolt mechanism of the steering lock is adequately lubricated during assembly and requires no periodical attention. However, the locking device can be lubricated occasionally to ensure smooth key operation but only with a little graphite dust. This may be introduced into the key slot on the key itself.

Warranty claims for jammed locking device barrels will be disallowed if upon examination the cause is found to be due to the presence of oil.

NOTE: The above precaution does not apply to the other external key-operated locks on the vehicle. This type can be lubricated periodically with a few drops of thin machine (cycle) oil as required to prevent the ingress of moisture and maintain easy key operation.

Item 10

SUBJECT: **STEERING COLUMN LOCK (Policy Item)**

MODEL: Series III Land-Rover.

PART NUMBERS:	Steering column lock and choke control assembly	1	589233	2½ litre	RH Stg	} Petrol models
	Steering column lock and choke control assembly	1	589232	2½ litre	LH Stg	
	Steering column lock and choke control assembly	1	589277	2.6 litre	RH Stg	
	Steering column lock and choke control assembly	1	589233	2.6 litre	LH Stg	
	Switch unit for ignition and lock	1	579085			} Diesel models
	Steering column lock and engine stop control ..	1	579491	2½ litre	RH Stg	
	Steering column lock and engine stop control ..	1	579422	2½ litre	LH Stg	
	Switch unit for heater and lock	1	579084			

REMARKS:

A number of complete steering column lock assemblies have been returned under warranty when only the ignition and lock switch on petrol models (heater and lock switch on diesel models) was known to be faulty. It is emphasised that the switch unit can be replaced separately from the main assembly. However, to gain access to the switch it will be necessary to remove the steering column lock first.

1. Disconnect the battery earth lead.
2. Disconnect the cold start control or engine stop control as applicable, in the engine compartment.
3. Remove the fixings and withdraw the steering column upper shroud.
4. Remove the fixings and move aside the lower shroud.
5. Centre punch and drill a hole in each sheared bolt to accept an extractor.
6. Remove the sheared bolts, using a suitable 'Easy-out' extractor.
7. Withdraw the steering column lock and retainer saddle.
8. Disconnect the electrical leads at the switch.
9. On petrol models, remove the single 'Posidrive' screw which retains the ignition and lock switch, as illustrated. The larger heater and lock switch used on diesel models is held by two 'Posidrive' screws. Both types of switch unit are provided with a keyway to ensure correct location on replacement.

Any warranty claims for replacement of a complete steering column lock assembly when only the switch is faulty will be disallowed.

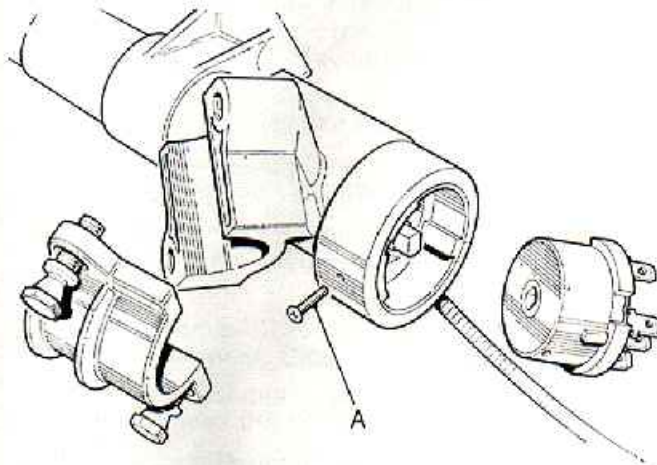

2RC168

Fig. 1 Steering column lock (petrol type illustrated)

A—Switch retaining screw



The Rover Company Limited, Solihull,
Warwickshire, England

June, 1972

INDEX

Description	Model	Issue No.	Item No.
Brake and clutch fluid	All	4	11
Low brake pedal/rear brake adjustment	109 long and 110 Forward Control	4	12
Speedometer cable incorrectly routed	Series III only	4	13

*Item contains suffix letter change.
Policy items printed in bold type.

Item 11

SUBJECT: BRAKE AND CLUTCH FLUID POLICY ITEM

MODELS: All Land Rover.

REMARKS: In Service Information, Land Rover petrol and diesel models, Vol. 1 No. 2, Item 5 we give information about the introduction of Unipart brake and clutch fluid 410 crimson. It must be clearly understood that the Unipart brake and clutch fluid does not supersede Castrol/Girling Brake and Clutch Fluid, Crimson but is an additional recommendation. Service literature will, in future, give both Castrol/Girling and Unipart brake and clutch fluid as alternative recommendations.

Item 12

SUBJECT: LOW BRAKE PEDAL/REAR BRAKE ADJUSTMENT

MODELS: Land-Rover 109 Long and 110 Forward Control

REMARKS: If low brake pedal is a problem in Service it has been found that an improvement can invariably be made by carrying out the simple adjustment procedure to the **rear brakes** as detailed below.

The adjustment should be carried out after:

- a. the normal checks on the hydraulic system have been made and
- b. the front brake shoes have been correctly adjusted in accordance with the Workshop Manual (110 in model) Repair Operation Manual (109 in model).

A second operator will be required to apply and release the foot brake as instructed by the operator who is adjusting in turn each of the rear brake shoe snail cams.

1. Raise the rear of the vehicle and place on stands.
2. Ensure the rear wheels turn freely.
3. With the foot brake firmly applied adjust **one** snail cam to its maximum position.
4. With the foot brake released, undo the cam one or two notches until the wheel just turns freely.
5. Repeat operations 3 and 4 on the remaining rear brake shoe snail adjuster.
6. Check the brakes for correct operation.
7. Lower the vehicle to the ground.

This operation centralizes the brake shoes to the drum without putting any excessive strain on the snail adjusters which could result in damage.

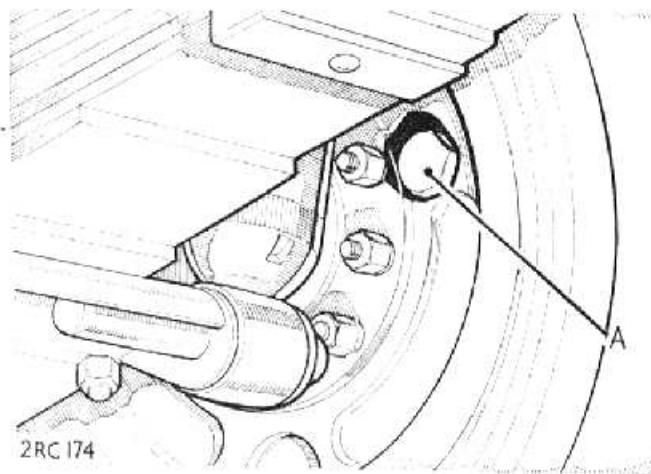

Fig. 1 Wheel brake adjustment

A—Adjuster bolt

Item 13

SUBJECT:

SPEEDOMETER CABLE INCORRECTLY ROUTED

MODEL:

Land-Rover Series III

REMARKS:

Service Department have received a few reports of incorrectly routed speedometer cables through the engine compartment bulkhead.

The flexible rubber panel has four grommet holes in it; viewed from left to right with the bonnet open from the front of the vehicle, the holes accommodate:

- A. Main body harness.
- B. Blanked off.
- C. Choke cable.
- D. Speedometer cable.

Some early Series III vehicles have the speedometer cable routed through the grommet hole which is normally blanked off. This incorrect assembly forces the cable through a sharp angle and can promote early speedometer inner cable failure.

Service Personnel should familiarise themselves with the correct layout as illustrated and give particular attention to this point when early Series III Land Rovers are inspected.

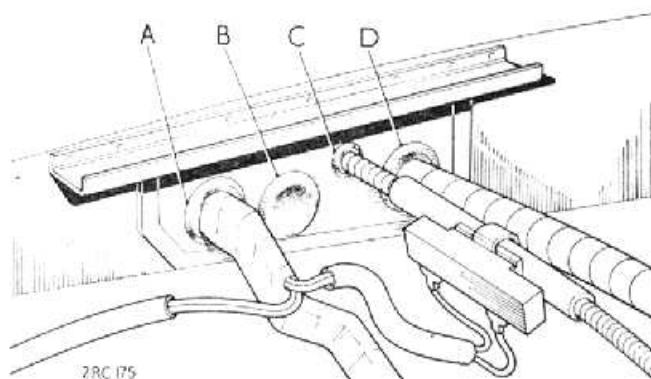

Fig. 2 Correct location of speedometer cable RH Stg. models

- A—Main body harness
- B—Grommet for blanked off aperture
- C—Choke cable
- D—Speedometer cable

SERVICE INFORMATION

Vol. 1 No. 5

LAND-ROVER PETROL AND DIESEL MODELS



The Rover Company Limited, Solihull,
Warwickshire, England

July, 1972

INDEX Vol. 1 Nos. 4 and 5

Description	Model	Issue No.	Item No.
Brake and clutch fluid	All	4	11
Brake and clutch fluid	All	5	14
Four-wheel drive selector rod bush	All	5	15
Hoses for radiator and heater	All	5	16
Low brake pedal/rear brake adjustment	109 long and 110 Forward Control	4	12
Speedometer cable incorrectly routed	Series III only	4	13

Policy items printed in bold type.

* Items contain suffix letter change.

Item 14

SUBJECT: **BRAKE AND CLUTCH FLUID (Policy Item)**

MODELS: Land Rover.

REMARKS: In Service Information, Land Rover petrol and diesel models, Vol. 1 No. 2, Item 5 we gave information about the introduction of Unipart brake and clutch fluid 410 crimson. It must be clearly understood that the Unipart brake and clutch fluid does not supersede Castrol/Girling Brake and Clutch Fluid Crimson but is an additional recommendation. Service literature will, in future, give both Castrol/Girling and Unipart brake and clutch fluid as alternative recommendations.

Item 15

SUBJECT: **FOUR-WHEEL DRIVE SELECTOR ROD BUSH**

MODELS: Land Rover.

REMARKS: Recent investigations into a complaint of inability to select four wheel drive high range revealed that the selector rod return spring became coil bound. This was caused because the external diameter of the bush was too large, which prevented the bush seating properly in the cover plate.

The bush should fit almost flush with the cover plate, but with incorrect tolerances it may be approximately 50 mm ($\frac{1}{2}$ in.) too high.

Should this condition be encountered we recommend that the cover plate be removed and the hole enlarged to accommodate the bush.

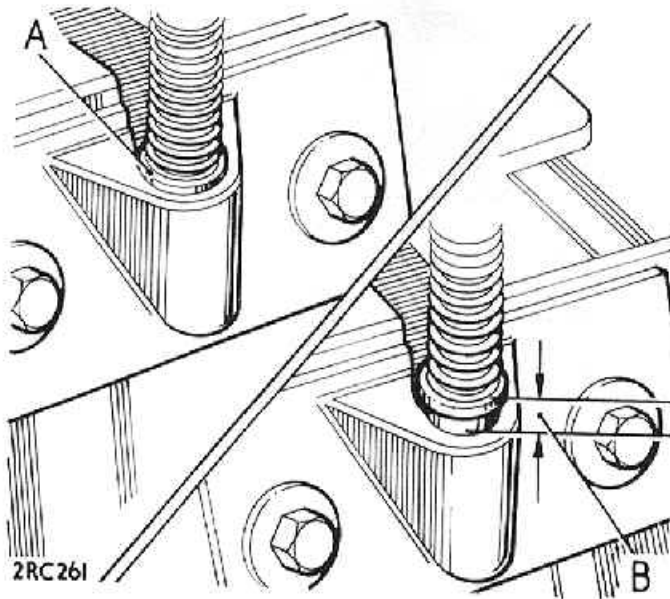

Fig. 1 Location of bush for 4-wheel drive selector rod

A—Bush correctly located in cover plate

B—Bush too high in cover plate which will cause the spring to become coil bound

Item 16

SUBJECT: HOSES FOR RADIATOR AND HEATER

MODELS: Land Rover.

REMARKS: Extensive rig tests have been carried out on radiator and heater hoses the duration of which would simulate a minimum vehicle service of seven years.

The results of these tests show that very few hoses had to be replaced due to ageing or temperature extremes.

The majority of failures were found to have been caused by damage in the area of the hose clip which occurs during removal and refitting of the hose as this imposes abnormal stresses on fabric which ultimately tears it. Over tightening of the hose clips will also result in this type of damage.

The above damage is not always apparent during servicing or examination as it can originate inside the bore.

In view of the expense and inconvenience incurred due to a hose failure it is suggested that:

- (a) Each hose be used not more than twice.
- (b) There is a closer internal examination for possible damage before replacement.
- (c) More care should be taken to align the hose during reassembly.

The clip impressions are normally significant in identifying how often a hose has been refitted.

SERVICE INFORMATION

LAND-ROVER PETROL AND DIESEL MODELS



Vol. 1 No. 6

The Rover Company Limited, Solihull,
Warwickshire, England

August, 1972

Item 16A

SUBJECT: EXPORTING PARTS BY HOME MARKET DISTRIBUTORS AND DEALERS (Policy Item)

REMARKS: There is evidence of increasing activity by organisations within the United Kingdom who wish to purchase Rover parts with the intention of ultimately exporting them. Attention is drawn to clause 4 of the Distributor and Retail Dealer agreements which requires Distributors and Dealers to use their best endeavours to ensure that parts sold by them will not be exported and to the penalties which could be incurred by Distributors and Dealers in breach of this agreement.

Item 17

SUBJECT: MAIN HARNESS, REPOSITIONING

MODEL: Land-Rover Series III 2½ litre Petrol

MODIFICATION: Introduction of modified main harness to prevent a foul condition between air cleaner, harness and wing valance.

PART NUMBERS: Main harness assembly 1 575373 RH Stg. 2½ litre Petrol
Main harness assembly 1 575408 LH Stg. 2½ litre Petrol
NOTE: part numbers unchanged.

COMMENCING NUMBERS:

Chassis serial numbers for modified main harness assembly.	
88 in. RH Stg. models from	90102343A onwards
109 in. Long RH Stg. models from	91100971A onwards
109 in. Station Wagon RH Stg. models from	93100345A onwards
88 in. LH Stg. models from	90401366A onwards
109 in. Long LH Stg. models from	91401821A onwards
109 in. Station Wagon LH Stg. models from	93401928A onwards

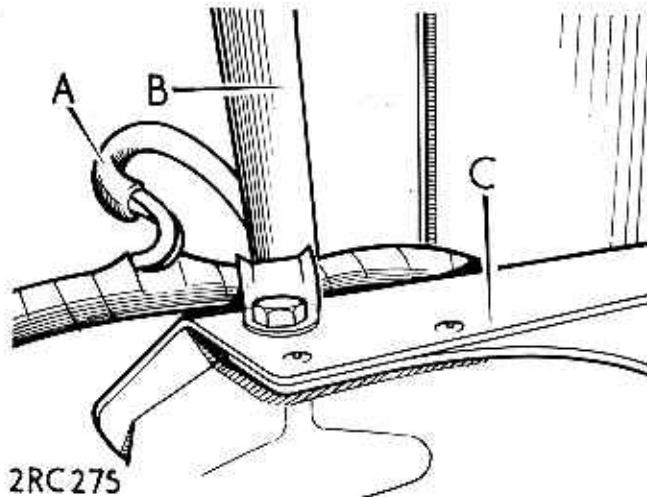

Fig. 1 Correct location of solenoid feed wire

A—Solenoid feed wire
B—Air cleaner
C—Wing valance

REMARKS: It has been brought to our attention that in certain instances a 'foul' condition may be present between the air cleaner, main harness assembly and the right hand side wing valance.

Service personnel are requested to examine all earlier vehicles, during routine maintenance checks and, if required, peel back the non-adhesive harness binding tape, thus allowing the solenoid feed wire to be re-routed away from the obstruction.

Should the solenoid feed wire be badly chafed, it should be replaced with the modified main harness assembly.

All Service stock of the main harness assemblies are to the latest specification.

Item 18**SUBJECT: ENGINE MISFIRE****MODELS:** All Land-Rover

PART NUMBERS: Coil to ignition lead 1 587968 Land-Rover 2½ litre
 Ignition lead set 1 574142 Land-Rover 2.6 litre

REMARKS: Several cases of engine misfire, and poor starting under wet or damp conditions have been reported and investigation has shown this to be caused by poor moulding of the right angled coil boot on the coil to distributor high tension ignition lead.

If this condition is detected or brought to your attention by an owner, on vehicles sold during the last 12 months, then the coil to ignition lead must be changed for the modified type, which has a moulding number stamped on the right angled coil boot. The earlier type has no moulding number.

Distributors and Dealers are requested to keep a careful watch for this condition during routine servicing.

In order that the cost of this action may be correlated, it is essential that all Warranty Claims contain code A326 in place of the normal Warranty Complaint Code.

The time allocated for this operation is 0.5 hours.

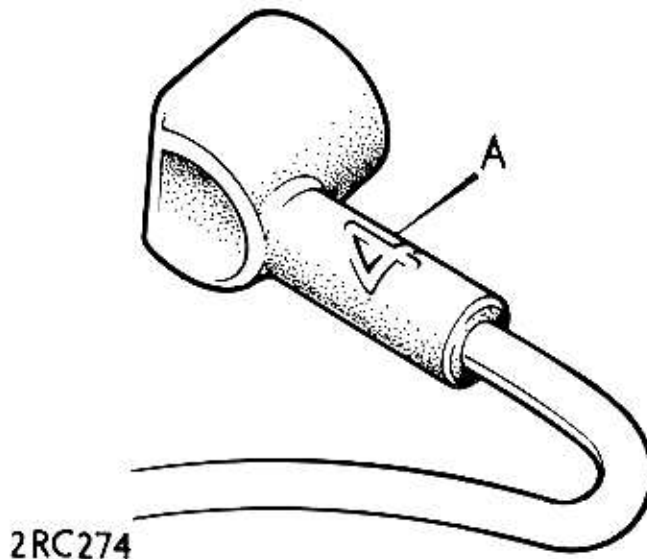
**Fig. 2 Identification of ignition lead**

A—Moulding number

Item 19**SUBJECT: ENGINE OVERHAUL GASKET KIT****MODELS:** All Land-Rover models with 2½ litre Petrol engines.**MODIFICATION:** Introduction of a modified engine overhaul gasket kit.

PCMI

TRANSPARENCY: The information detailed in this item will be incorporated in the next available transparency.

PART NUMBER: Engine overhaul gasket kit 1 608124

REMARKS: The latest gasket kit re-establishes the provision of self-locking nuts for the connecting rod caps and also provides the various lock washers required on engine overhaul. When stocks of the previous kit, Part No. 525856, are exhausted, the latest gasket kit only will be stocked by the Parts Department.

Item 20

SUBJECT: **REPAIR TIMES SCHEDULE**

MODELS: Land-Rover, Series IIA and III.

MODIFICATION: Introduction of up-dated and more comprehensive Repair Times Schedule in the A4 format.

PART NUMBER: Repair Times Schedule, English 1 607623

REMARKS: The above publication has been despatched during the week commencing 19th June 1972 on the following basis.

(1) United Kingdom

Distributors: 2 free of charge copies.

Dealers and Fleet Users, where appropriate: 1 free of charge copy.

Additional copies are available from our Parts Department at Cardiff, price £2.20 nett.

(2) Overseas

Two free of charge copies to each Distributor.

The following points should be noted as far as Dealer requirements are concerned. All Overseas Distributors are entitled to apply to: The Rover Company Ltd. Technical Service Dept. Publications Section, Lode Lane, Solihull, Warwickshire, England, for additional free of charge copies on the basis of one for each of their Dealers and Fleet Users, where applicable. Further copies, if required, are available from our Parts Department at Cardiff, price £2.20 nett.

Distributors in non-English speaking areas should note that during 1973 the Repair Times Schedule will be issued in:

French
German
Italian
Spanish
Swedish
and at a later date also in
Danish
Dutch
Finnish
Portuguese

Distributors are asked to bear this in mind when applying for additional copies of the English version.

Ordering procedure

All requests from Dealers and Fleet Users in the U.K. and Overseas markets MUST be made through the Distributor responsible for the zone or country.

SERVICE INFORMATION

Vol. 1 No. 7

LAND-ROVER PETROL AND DIESEL MODELS



The Rover Company Limited, Solihull,
Warwickshire, England

September, 1972

The headings in this index are in the same sequence as the divisions in the Repair Operation manual. Under these headings each item is detailed alphabetically with the appropriate manual section or division number for easy reference. The last two columns indicate numerically the individual items covered and the issue in which they appeared.

INDEX Vol. 1 No. 7

Description	Manual Section or Division	Model	Issue No.	Item No.
Gearbox Gear lever ball-end	{ C 37	Series IIA Series III	7 7	23 23
Electrical Battery replacement	{ N 86	Series IIA Series III	7 7	21 21
Miscellaneous Parts identification	—	All	7	22
P C M I Reader (MOD 6)	—	All	7	24

Policy items printed in bold type.

*Items contain suffix letter change.

Item 21

SUBJECT: **BATTERY REPLACEMENT (Policy Item)**

MODELS: All Land-Rover.

REMARKS: Concern is felt at the number of Warranty Claims received in respect of batteries, even though these items are not covered by the Rover Warranty.

The current Owner's Service Statement stipulates that batteries are excluded from our Warranty.

However, the Rover Company continues to receive Warranty Claims in respect of defective batteries.

It must be clearly understood that any batteries which give cause for complaint during the Warranty period should be returned under Claim to the manufacturer's local agent.

If, in contravention of this instruction, batteries are returned to the Rover Company under Claim, the Claim will be rejected and in view of the problems and cost involved in transporting such components, they will be consigned to scrap.

Item 22

SUBJECT: **PARTS IDENTIFICATION (Policy Item)**

MODELS: All Land-Rover.

REMARKS: It is known that certain vehicle manufacturers utilise casting and forging numbers on components as part numbers. This practice does not apply to Rover products since different components may be produced from identical castings. This is especially so in view of the new metric dimensioned parts which may be similar to inch types.

Item 23**SUBJECT: GEAR LEVER BALL END****MODELS:** Series IIA and III Land-Rover**PART NUMBERS:** Gear change lever with ball end only:

4 cylinder models, R H Stg	1	571666
4 cylinder models, L H Stg	1	571667
6 cylinder models, R H Stg	1	576576
6 cylinder models, L H Stg	1	576577

REMARKS:

Over a period of time there have been instances of failure of the Polyurethane material used for the ball end attached to the gear lever on Series IIA vehicles.

Since last November this material, which is also used currently on the Series III, has been subjected to additional laboratory tests to ensure its consistency with our specification.

Any future recurrence of this problem should be satisfactorily remedied by fitting a replacement gear lever.

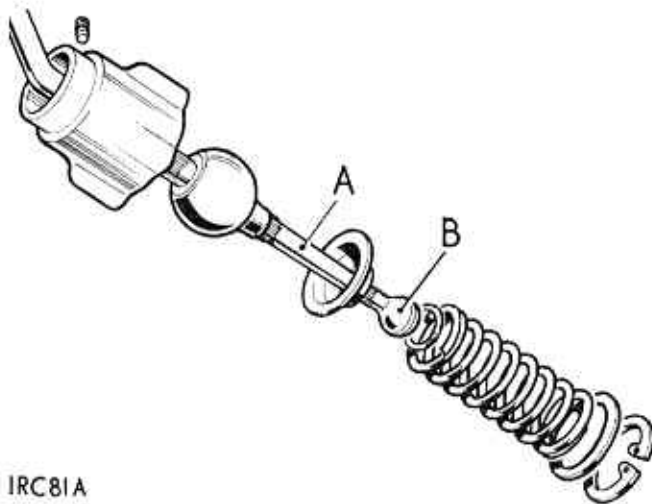

IRC81A

Fig. 1 Gear lever assembly

A—Gear change lever
B—Ball end

Item 24**SUBJECT: P C M I READER (MOD 6)****MODELS:** All Land-Rover.**REMARKS:**

A new P C M I Reader, MOD 6, is now available from our Parts Department at Cardiff in addition to the existing MOD 5. Dealers should place orders for either model through their local Distributor in the usual way.

The construction of the new MOD 6 version is similar to the existing MOD 5 but also incorporates the following new features:

1. The transparency holder is fitted with two movement control knobs.
2. The silver coloured base plate is reinforced in the area of the light aperture.
3. The black Y bar, (to which the transparency holder is attached) is now mounted on a ball bearing traverse.

The effect of these design changes is to give greater stability to the transparency holder itself, thereby reducing the need for focal adjustment.

SERVICE INFORMATION

Vol. 1 No. 8

LAND-ROVER PETROL AND DIESEL MODELS



Rover
British Leyland UK Limited,
Solihull, Warwickshire, England

October, 1972

The headings in this index are in the same sequence as the divisions in the Repair Operation Manual. Under these headings each item is detailed alphabetically with the appropriate manual section or division number for easy reference. The last two columns indicate numerically the individual items covered and the issue in which they appeared.

INDEX Vol. 1 Nos. 7 and 8

Description	Manual Section or Division	Model	Issue No.	Item No.
Fuel System Bendix fuel pump	19	Series III 109 in. 2.6 litre	8	29*
Gearbox—synchromesh Gear lever ball-end	{ C 37	Series IIA Series III	7 7	23 23
Electrical Battery replacement	{ N 86	Series IIA Series III	7 7	21 21
Boost starting vehicles	{ N 86	Series IIA Series III	8 8	25 25
Miscellaneous Exchange Parts and Units	—	Petrol engines, 1955/61 Gearbox, 1954	8	26
Parts identification	—	All	7	22
PCMI Reader (MOD 6)	—	All	7	24
PDI Forms	—	All	8	26A
Repair Operation Manual	—	Series III	8	32
Return of Rover Warranty material	—	All	8	27
Service publications	—	All	8	28
Service Tools Service tool for differential Rover type axles only	{ Z 99	Series II, IIA Series III	8 8	30 30
Service tool for front hub	99	Series III	8	31

Policy items printed in bold type.

*Items contain suffix letter change.

Item 25

SUBJECT: BOOST STARTING VEHICLES (Policy Item)

MODELS: All Land-Rover

REMARKS: It has been brought to our attention that a practice exists where a 24 volt battery is introduced into a 12 volt system to aid starting. Distributors and Dealers are advised that such a practice is totally unacceptable and will almost certainly cause irreparable damage to electrical components. It should also be observed that the battery in any vehicle fitted with an alternator must not be 'boost' charged, while it is connected to the vehicle's electrical system or the internal components of the alternator will be damaged.

NOTE. When charging a battery ensure that the voltage setting on the charging equipment is the same as the battery rating and that parallel polarity is maintained. Should any electrical components be returned to this Company in support of Warranty Claims, and it is subsequently proved that these have been subjected to a substantial voltage over-load attributed to either of the above causes, the associated claims will be cancelled or disallowed, as appropriate, and the components returned to the Distributor or Dealer concerned.

Item 26

SUBJECT: EXCHANGE PARTS AND UNITS (Policy Item)

MODELS: Land-Rover Petrol engine.
Land-Rover gearbox.

MODIFICATION: Withdrawal from Exchange Scheme of two engines and one gearbox.

PART NUMBERS:

Engine assembly, petrol	1	269217	1955-58
Engine assembly, petrol	1	524139	1958-61
Gearbox assembly	1	522776	1954

REMARKS: In view of the reduced demand the above replacement major units have been withdrawn from the Exchange Scheme. However, individual engine and gearbox components for these models are still available from our Parts Department at Cardiff.

Item 26A

SUBJECT: P D I FORMS, UK ONLY (Policy Item)

MODELS: All Land-Rover.

LITERATURE AFFECTED: Service Policies and Procedure Manual, Part No. AKD 8000, January, 1972, page 16, paragraph 2 refers.

PART NUMBER: Pre-Delivery Inspection form AKD 8001

REMARKS: Recently a number of P D I forms have been returned to the Rover-British Leyland UK Ltd. It is emphasised that P D I forms must be retained by Franchise Holders in their vehicle master file in accordance with the procedure outlined in the Manual. See reference above.

Item 27

SUBJECT: RETURN OF ROVER WARRANTY MATERIAL (Policy Item)

MODELS: All Land-Rover.

REMARKS: All overseas Distributors and British Leyland Companies are further reminded of the correct procedure to adopt before returning warranty displaced materials to this Company, as outlined in Land-Rover Service News Letter Volume 3, No. 14, Item 101. Prior authority must be obtained from Technical Service Department, Service Division, or the Area Service Representative before the parts are despatched.

Where approval is given by the Company for such materials to be returned for special investigation, it is essential that there is adherence to the following procedure:

1. Notify Rover-British Leyland UK Ltd., Technical Service Department, when shipment has been effected, detailing the method of transport used and quoting any appropriate references.
2. Submit a free of charge invoice in duplicate, itemising the parts that are being returned and quoting a nominal value for the parts for customs purposes.
3. Where the delivery of parts is by sea transport, bills of lading should be forwarded, together with the invoices required under paragraph 2.
4. Where parts are despatched by air, in addition to two copies of the invoices required under paragraph 2, an additional copy should be sent forward with the airway bill.

Because of the confusion and expense in which this Company is involved when parts are returned without prior notification and without proper documentation being sent forward, it is necessary to again stress to all Overseas Companies and Distributors the importance of adhering to the above instructions.

Where parts are returned without the appropriate authority or documentation being submitted, the Company will be unable to assume responsibility for costs and customs clearance and this could involve Overseas Distributors and Companies in considerable expense which, in their own interests, should be avoided.

In certain instances where a proprietary manufacturer is carrying out a specific investigation, a request may be made for the displaced parts to be forwarded direct to the manufacturer concerned. In such a case, the same procedure should be adopted, but any invoices may be submitted to the manufacturer concerned and both the manufacturer and Rover-British Leyland UK Ltd., Technical Service Department should be notified of the despatch details.

Item 28

SUBJECT: SERVICE PUBLICATIONS (Policy Item)

MODELS: All Land-Rover.

LITERATURE AFFECTED: Technical Literature Catalogue, Part No. AKD 8033, Issue 1.

REMARKS: We receive many requests for various Rover publications direct from owners. It seems that in most cases they have been unable to obtain the required literature from their Distributors or Dealers.

Supplies of all the publications shown in the British Leyland Technical Literature Catalogue, AKD 8033, are readily available to Distributors and Dealers from the Rover Parts Department at Cardiff.

While it is appreciated that Distributors and Dealers cannot maintain large stocks of all publications they should endeavour to keep a selection of those for which there is a regular demand.

Copies of the Technical Literature Catalogue are available from:

Rover
British Leyland UK Ltd.,
Technical Service Dept.,
Publications Section,
Solihull,
Warwickshire,
England.

Item 29

SUBJECT: **BENDIX FUEL PUMP**

MODELS: Land-Rover Series III 109, 2.6 litre.

MODIFICATION: Introduction of Bendix electric fuel pump, replacing the S U fuel pump previously used, to overcome problems of corrosion.

P C M I

TRANSPARENCY: The information detailed in this item will be incorporated in the next available transparency.

LITERATURE

AFFECTED: Land-Rover Series IIA Parts Catalogue, Part No. 608024, page 04.41.
Land-Rover Repair Operation Manual (English) Part No. 607314 operation 19.45.08.

PART NUMBERS:	Electric fuel pump	1	568189	} Part of 568189	
	Filter for pump	1	606262		
	Gasket for filter	1	606261		
	Lucrimp connector	1	536937		
	Mounting bracket for pump	1	598575		
	Bolt ($\frac{1}{2}$ in. UNF x $\frac{3}{8}$ in.)	} Fixing bracket to frame						...	1	255206	
	Spring washer	}						...	1	3074	
	Nut ($\frac{1}{2}$ in. UNF)	}						...	1	254810	
	Braid strip	} Fixing pump to bracket						...	1	568244	
	Fan disc washer	}						2	510170		
	Plain washer	}						...	2	3840	
	Spring washer	}						4	3074		
	Nut ($\frac{1}{2}$ in. UNF)	}						4	254810		
	Rubber mounting	}						2	570491		
	Grommet at rear body bracket mounting	1	272512		
	Adaptor on pump	2	572535		
	Fuel pipe, pump to filter	1	595339		
	Fuel pipe, tank to pump	1	595340		
	Cable assembly, coil to pump	1	589570		

COMMENCING
NUMBER:

Chassis suffix letter change:

Land-Rover 109, Series III, 2.6 litre models from suffix B onwards.

REMARKS:

The Bendix fuel pump is being fitted to current Land-Rover 109 vehicles with 2.6 litre engine.

It is important therefore that stocks of the relevant parts are obtained as required from our Parts Department to ensure that Service requirements can be met.

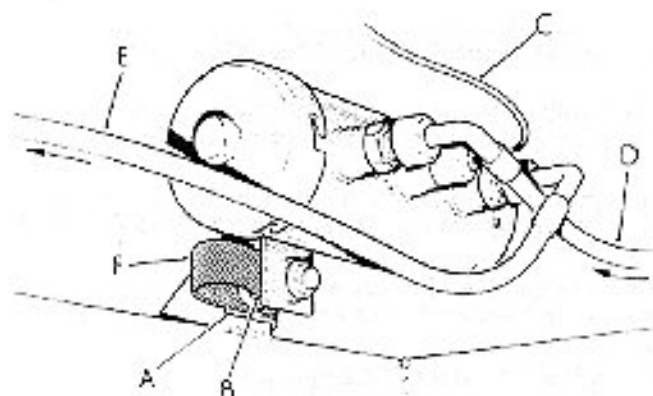

287 209

Fig. 1 Fuel pump installation

A—Pump mounting bracket	D—Inlet pipe from tank
B—Rubber mounting	E—Outlet pipe to filter
C—Feed wire	F—Earthing strap

Item 30

SUBJECT: SERVICE TOOL FOR DIFFERENTIAL (Rover type axles only)

MODELS: Land Rover Series II, IIA and III.

MODIFICATION: Introduction of a lengthened centre bolt for the differential pinion head bearing removal tool; the associated press block has also been modified to give improved contact with the head bearing. The centre bolt length has been increased from 180 mm (7 in.) to 230 mm (9 in.); press block diameter increased from 69 mm (2.7 in.) to 77 mm (3.0 in.).

**LITERATURE
AFFECTED:**

Land Rover Series II and IIA Workshop Manual, English, Part No. 606408, Operation E1-14.

Land-Rover Series III Repair Operation Manual, English, Part No. 607314, Operation 54.1007.

PART NUMBERS:

Removal tool for pinion head bearing	1	262757A
Centre bolt, long, part of 262757A	1	262757A detail 3
Press block for pinion head bearing	1	262757-1

REMARKS:

On all Series III models and at the vehicle suffix letter change from 'G' to 'H' on Series IIA models, the pinion oil seal retainer is integral with the differential casing and not removable as previously; therefore a longer centre bolt has been provided for the Service tool used to remove and refit the pinion head bearing cup, to cater for the extra depth of casing involved.

Lengthening the centre bolt has resulted in a tool number change from 262757 (which remains suitable for early models) to 262757A which is suitable for both early and late models. The longer centre bolt is available separately under Part No. 262757A detail 3 to enable holders to modify their original tool Part No. 262757 which is then suitable for both early and late models.

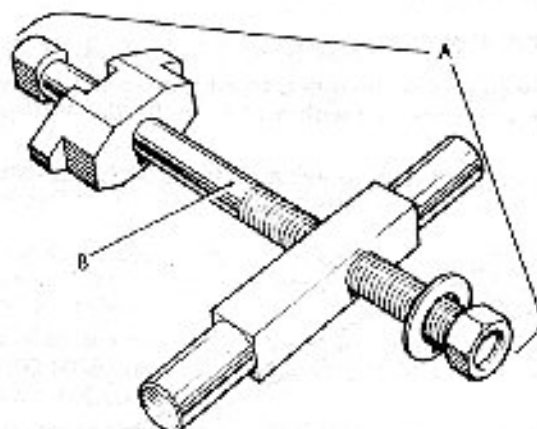

28C516

Fig. 2 Removal tool for pinion head bearing

A—Tool 262757A complete

B—If required centre bolt only obtainable separately under Part Number 262757A detail 3

In conjunction with the above modification, the opportunity has been taken to provide a new press block which gives a greater contact area with the pinion bearing cup. The new press block Part No. 262757-1 replaces the earlier press block Part No. 262758 for the following models:

Land Rover Series IIA with axle serial numbers from Suffix 'B' onwards, and all Land Rover Series III models.

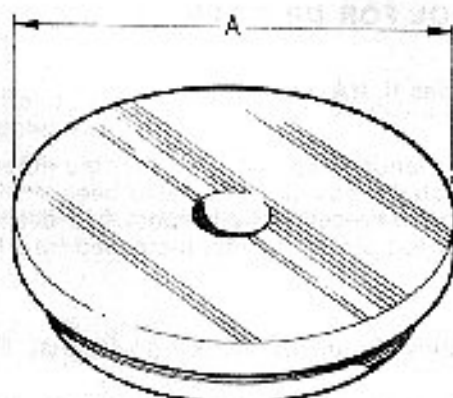

2RC 337

Fig. 3 Press block for pinion head bearing

A—Early tool Part No. 262758 measures 69 mm (2.7 in.).
Later tool Part No. 262757-1 measures 77 mm (3.0 in.)

The literature affected will be revised accordingly at the next available reprint.

All orders for the above tools must be sent to:

Messrs. V. L. Churchill & Co. Ltd.,
PO Box No. 3,
London Road,
Daventry,
Northants, NN11 4NF.

Item 31

SUBJECT: **SERVICE TOOL FOR FRONT HUB**

MODELS: Land-Rover Series III.

MODIFICATION: Introduction of a Service tool for removing/refitting the circular castle nut which retains the front hub driving member and the axle stub shaft.

LITERATURE AFFECTED: Land-Rover Series III Repair Operation Manual, English, Part Number 607314, Operation 60.25.01 and Division 99 (Service tools).

PART NUMBER: Spanner for stub shaft nut 1 R01010

REMARKS: The above Service tool is designed to engage in the castellations of the circular castle nut. The free end is provided with a 12.7 mm (0.500 in.) square hole to accept a suitable wrench.

The tool is suitable for use on vehicles fitted with free-wheeling hubs.

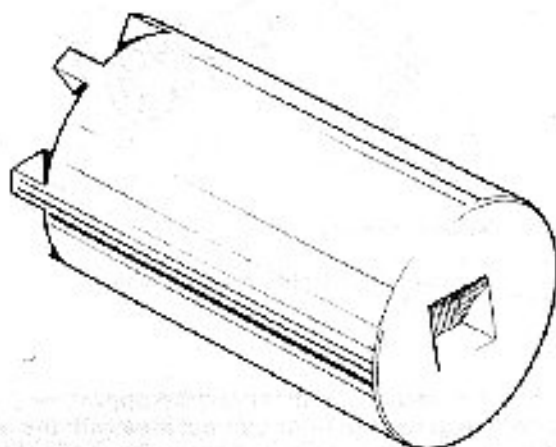

2RC 326

Fig. 4 Spanner for stub shaft nut

The literature affected will be revised accordingly at the next available reprint.

All orders for the above tool must be sent to:

Messrs. V. L. Churchill & Co. Ltd.,
PO Box No. 3,
London Road,
Daventry,
Northants, NN11 4NF.

Item 32

SUBJECT: REPAIR OPERATION MANUAL

MODELS: Land-Rover Series III.

REMARKS: The Supplement which brings the Land-Rover Series III Repair Operation Manual, Part No. 607214, completely up to date has been issued in accordance with the original circulation of the Manual.

Supplements for any additional Manuals which may have been purchased for your own use or for resale to customers can be obtained free of charge from Rover-British Leyland UK Limited, Lode Lane, Solihull.

Translated versions of this Supplement will be available at a later date.



Rover
British Leyland UK Limited,
Solihull, Warwickshire, England

November, 1972

Item 33

SUBJECT: FROST PRECAUTIONS (Policy item)
MODELS: All Land-Rover
MODIFICATION: Introduction of frost precautions instructions for the winter 1972/73.
REMARKS: Company policy with regard to the use of anti-freeze mixtures in our products remains basically the same as in previous years. For comprehensive details on this subject see Service News Letter, Volume 3, number 29, item 160, issued in November 1971.

Item 34

SUBJECT: ENGINE MISFIRE
MODELS: All Land-Rover
PART NUMBERS: Coil to distributor HT lead 1 587968 2½ litre
HT lead set 1 574142 2.6 litre

IDENTIFICATION: Moulding number 4 (see illustration below).

REMARKS: We would draw your attention to the comments made in Service Information Vol. 1 No. 6 Item 19, regarding engine misfire and indifferent starting under wet or damp conditions owing to poor moulding of the right-angled boots on a batch of H.T. leads. According to our records only a small response has been made to this information. It is, however, anticipated that the forthcoming winter will aggravate the problem and you are therefore requested to pay particular attention to this point at routine service periods or if a particular criticism is made by an owner. It is essential that any warranty claims for rectification arising from this action contain Code A326 in place of the normal warranty complaint code in order that costs may be correlated. Warranty claims for rectification will not be accepted after 5th February 1973.

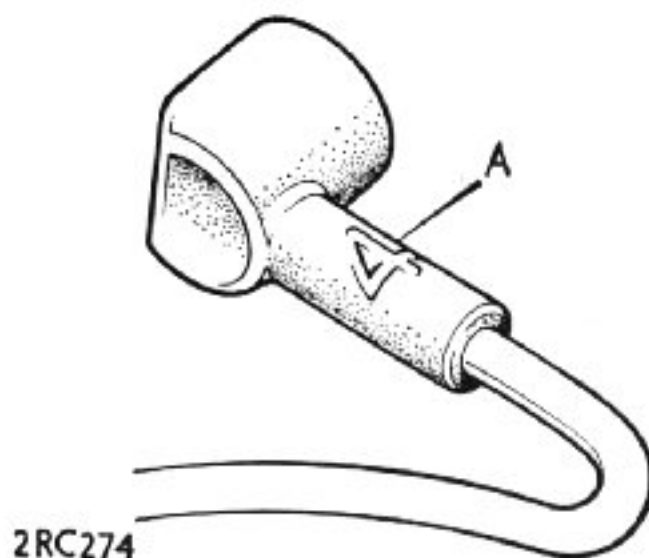

Fig. 1 Identification of moulded 'boot' on coil to distributor HT lead
A—Moulding number

Item 35**SUBJECT: CLUTCH RELEASE MECHANISM****MODELS:** Land-Rover Series IIA models fitted with all-synchromesh gearbox
Land-Rover Series III**MODIFICATION:** Introduction of a new clutch release bearing and sleeve assembly.**P C M I****TRANSPARENCY:** Information on this subject has already been included in an earlier transparency but will be re-issued to show the parts as an assembly, as detailed below.**LITERATURE****AFFECTED:** Land-Rover Series III Parts Catalogue Supplement Part No. 608049, page 16.43.
Land-Rover Repair Operation Manual, Part No. 607314, Operation 33.25.12.
Land-Rover Workshop Manual Supplement, Part No. 607288, Operation 33.25.12.**PART NUMBER:** Clutch release bearing and sleeve assembly 1 594271**COMMENCING
NUMBERS:**

Gearbox serial numbers:

Series III all 88 and 109 Long and Station Wagon 2½ petrol and diesel from 90140228A onwards.

Series III, 109 Long and Station Wagon 2.6 petrol from 94103462A onwards.

Series III 109, one ton, 2½ petrol from 24600063A onwards.

Series III, 109 one ton, 2.6 petrol from 26600184A onwards.

REMARKS:

The above modification has been introduced to reduce the possibility of the clutch release sleeve becoming seized on the front cover extension during arduous driving conditions and to improve the bearing lubrication.

The assembly comprises a sleeve manufactured from 'Ferrobestos' and a new release bearing which is packed with grease and sealed. These are bonded together by Loctite high strength retaining compound.

The assembly is interchangeable with the earlier bearing and sleeve but is only available as a complete assembly.

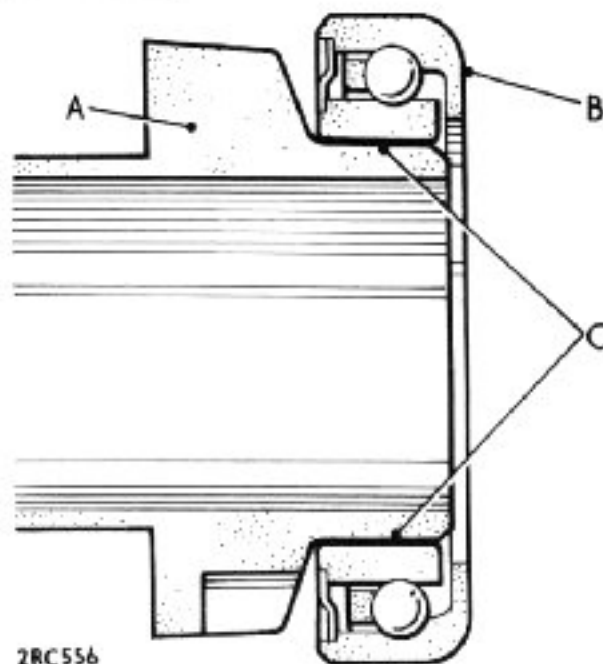
**Fig. 2 Clutch release bearing and sleeve assembly**A—'Ferrobestos' sleeve
B—Sealed bearing
C—'Loctite' bonded joint

Item 36SUBJECT: **DOORS**

MODELS: Land-Rover Series II and IIA

MODIFICATION: Addition of a pivot bracket to convert a Series III door to fit Series II and IIA vehicles.

PART NUMBERS:	Pivot bracket assembly, RH	1	347338	
	Pivot bracket assembly, LH	1	347339	
	Screw	4	255226	
	Washer, plain	} Fixing pivot bracket assembly to intermediate member on door frame	..	4	3446
	Washer, spring		..	4	3075
	Nut		..	4	254821

REMARKS: To enable a Series III type door to be used on Series II and IIA vehicles the above assembly is bolted on to the intermediate member already provided on the Series III door frame for check strap attachment.

NOTE: Since difficulty has been experienced in locating and retaining the nuts in the intermediate member while tightening the bracket fixing screws, a nut plate assembly Part No. 347511 will eventually be supplied for this conversion in place of the four plain washers and nuts specified above.

In the meantime it is recommended that a nut plate is manufactured to facilitate assembly.

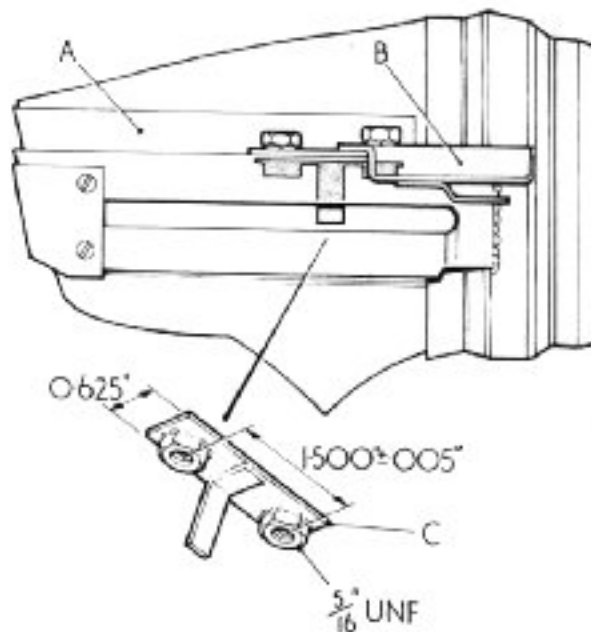

2RC568

Fig. 3 Pivot bracket conversion

A—Intermediate member for Series III door frame
 B—Pivot bracket assembly
 C—Nut plate

Item 37SUBJECT: **PARTS CATALOGUE**

MODELS: Land-Rover Forward Control, Series IIA and IIB

PART NUMBER: Land-Rover Forward Control, Series IIA and IIB Parts Catalogue 1 608218

REMARKS: This new publication, Part No. 608218 is now available from our Parts Department at Cardiff at a nominal price of £1.75 nett. The recommended retail price is £2.00. Dealers should note that their requirements must be ordered through their Distributor. Non-observance of this will lead to administrative complications. The new catalogue up-dates the information contained in the previous version, Part No. 4862, which it replaces.

Item 38

SUBJECT: **TOOL BOARD**

MODELS: All Land-Rover

PART NUMBER: Tool board, Leycare 1 45LC

REMARKS: A tool board not only keeps the workshop tidy but helps to avoid tool losses and simplifies stocktaking. The tool board illustrated includes a separate wire mesh steel cage which enables the tools to be covered. It is attached to the board by locating spigots at the top and a hasp device at the bottom which can be padlocked for security. The boards, which measure 900 x 650mm (35½ x 25½in), are manufactured from 1.28mm (18 SWG) perforated steel sheet with edges and have welded corners for added strength and rigidity. They have a durable cellulose finish. Edges can be drilled and boards bolted together if required. The range of clips and brackets illustrated are supplied in sets of ten, complete with the necessary fixing nuts and bolts. They are designed to support a wide range of shapes and sizes of tools and are robust enough to support the heaviest service tools. Churchill special tools are supplied with neat plastics labels which can be affixed to the board. These tool boards can only be obtained direct from:
 V. L. Churchill and Company Limited
 P. O. BOX 3
 London Road
 Daventry
 Northants NN11 4NF
 Telephone: 03-272 4461 Telex: 31326

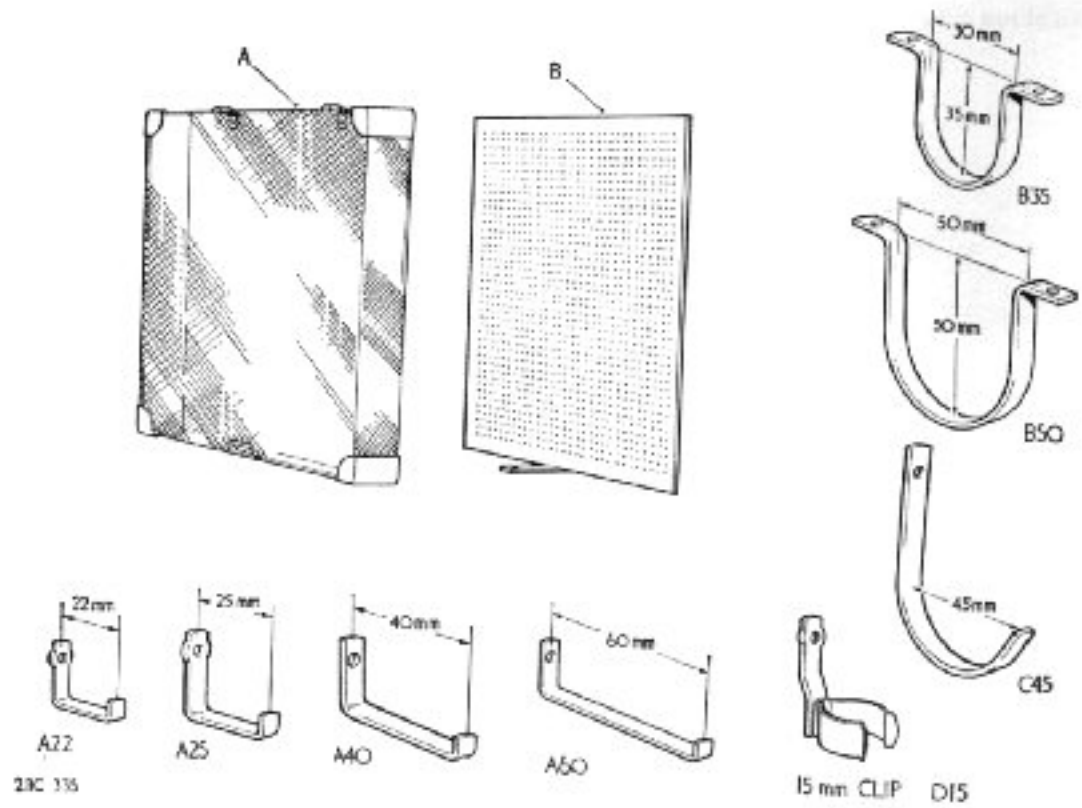

Fig. 4 Tool board
 A—Wire mesh cover
 B—Tool board



Rover
British Leyland UK Limited
Solihull, Warwickshire, England

The headings in this index are in the same sequence as the divisions in the Repair Operation Manual. Under these headings each item is detailed alphabetically with the appropriate manual section or division number for easy reference. The last two columns indicate numerically the individual items covered and the issue in which they appeared.

INDEX Vol. 1 No. 10

Description	Manual Section or Division	Model	Issue No.	Item No.
COOLING SYSTEM Cooling system	26	Series III	10	39
MANIFOLD AND EXHAUST SYSTEM Inlet manifold	30	Series III diesel with servo-assisted brakes	10	40
FRONT SUSPENSION Distance piece for inner hub bearing	F 60	Series IIA Series III	10 10	41 41
REAR SUSPENSION Distance piece for inner hub bearing	E 64	Series IIA Series III	10 10	41 41
BODY Windscreen pivot arm	76	Series III	10	42
ELECTRICAL Parking lights	N 86	Series IIA Series III	10 10	42A 42A
OPTIONAL EQUIPMENT Auxiliary battery charging conversion kit	90	Series III 88 in and 109 in	10	43
MISCELLANEOUS E C A procedure (UK only)	—	All	10	38A

* Item contains suffix letter change.
Policy items printed in bold type.

Item 38A

SUBJECT: E C A PROCEDURE, UK ONLY (Policy item)

MODELS: All Land-Rover.

REMARKS: Exceptional Claim Authorisation requests are still being received direct from Dealers. All Franchise Holders are, therefore, reminded that ECA's must be submitted VIA A ROVER DISTRIBUTOR, whose name and address is to appear on the face of this document, as having checked and verified it.

Item 39SUBJECT: **COOLING SYSTEM**

MODEL: Land-Rover Series III.

REMARKS: During a recent investigation a large number of thermostats returned under Warranty, were examined for alleged faults. All but two were found to exhibit no fault whatsoever, the remaining two being damaged externally, that is damaged during removal or transit. Distributors and Dealers are requested to ensure that the testing procedure, laid down in the respective Workshop Manuals is adhered to in order to obviate any further unnecessary expense.

Warranty Claims covering the replacement of thermostats and which are subsequently found to be serviceable, will be disallowed in accordance with normal procedure.

Item 40SUBJECT: **INLET MANIFOLD**

MODEL: Land-Rover Series III diesel with servo-assisted brakes.

REMARKS: A small number of cases have been reported where the clamp screw, which locks the operating lever to the butterfly valve, has come loose.

If this condition is present on a vehicle, it can cause either a loss of vacuum or excessive smoke to be emitted from the exhaust. Should Distributor or Dealer personnel come across this problem they are advised to first check the positioning and tightness of the clamp screw. If the component is found to be loose it is recommended 'Studlock' or 'Loctite' is applied and the screw re-tightened.

Production Department, as an interim measure, from April, 1972, have been applying 'Studlock' on the screw. To overcome this possible condition permanently, however, it is anticipated that a re-design of the particular area concerned will be carried out.

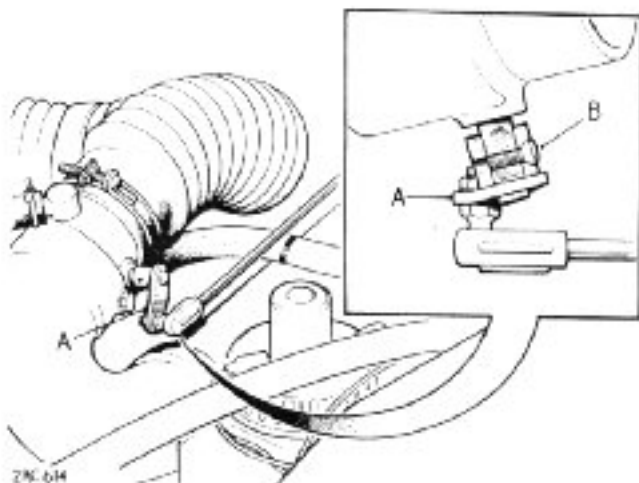

Fig. 1 Inlet manifold butterfly valve

A—Operating lever
B—Clamping screw

Item 41SUBJECT: **DISTANCE PIECE FOR INNER HUB BEARING**

MODELS: Land-Rover Series IIA and III.

MODIFICATION: Introduction of mild steel distance piece to eliminate oil leaks arising from previous sintered iron type.

PCMI

TRANSPARENCY: The following information will be incorporated in the next available transparency.

LITERATURE
AFFECTED:

Land-Rover Series IIA Parts Catalogue, Part No. 608024, pages 04.55 and 04.77.
 Land-Rover Series III Parts Catalogue, Part No. 606849, page 16.31.
 Land-Rover Workshop Manual (part two) English, Part No. 606408, Operations F1.5 and E1.6.
 Land-Rover Repair Operation Manual, English, Part No. 607314, Operations 60.25.24 and 64.15.21.

PART NUMBERS:	Rear hub bearing assembly	2	599828	88 and 109
	Front stub axle assembly	2	599826	88 only
	Front stub axle assembly	2	599827	109 only
	Distance piece for inner hub bearing	2	599698	Part of above assemblies

COMMENCING
NUMBERS:

Axle serial numbers
 Series III, 88 front, RH Stg from 90114862B onwards.
 Series III, 88 front, LH Stg from 90416794B onwards.
 Series III, 88 rear from 90131631A onwards.
 Series III, 109 2½ litre, front, RH Stg from 91127432B onwards.
 Series III, 109 2½ litre, front, LH Stg from 91418757B onwards.
 Series III, 109 2.6 litre front, RH Stg from 94105049B onwards.
 Series III, 109 2.6 litre front, LH Stg from 94402825B onwards.
 Series III, 109 2½ and 2.6 litre rear, (Salisbury axle) from H72-3567 onwards.

REMARKS:

A number of Land-Rover owners have experienced hub oil leaks which, in most cases, may be attributed to the sintered iron type inner bearing distance piece, Part No. 217351. This may be subject to splitting in service and cases of porosity have been reported, believed to be due to surface cracking.

Where hub oil leaks are due to this condition the inner bearing distance piece can be removed as described in the appropriate manual operation listed above and replaced with the latest mild steel type, Part No. 599698, ensuring that Bostick 772 is applied liberally to the inner circumference and the tapered surface which faces the back plate.

NOTE: Because of the material change the mild steel distance piece cannot be removed in the same way as the sintered iron type.

In this case, it is recommended that, by exercising reasonable care the distance piece can be partially cut through with a sharp chisel to loosen it, when it can be gently prised off.

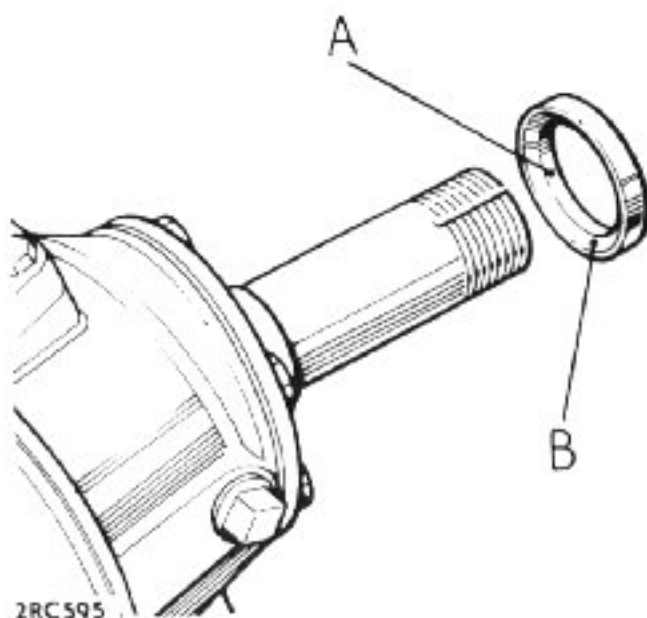

Fig. 2 Distance piece for inner hub bearing

A—Apply Bostik 772 to inner circumference
 B—Apply Bostik 772 to tapered surface

Item 42SUBJECT: **WINDSCREEN PIVOT ARM**

MODEL: Land-Rover Series III.

MODIFICATION: Change of washer material.

PCMI

TRANSPARENCY: The information detailed in this item has already been included in the current transparency.

LITERATURE

AFFECTED: Land-Rover Series III Parts Catalogue Supplement, Bonneted Control models, Part No. 608049, page 16.76.

PART NUMBER: Copper washer for windscreen pivot 2 232038

REMARKS: In certain instances the fibre washer between the windscreen and the pivot arm cracks after initial tightening and during service this washer is displaced by vibration, thereby allowing movement between the windscreen assembly and the windscreen pivot arm. The eventual consequences of this condition is a cracked or broken windscreen pivot arm. The fibre washer has now been replaced by a copper washer and this should be used for all replacements.

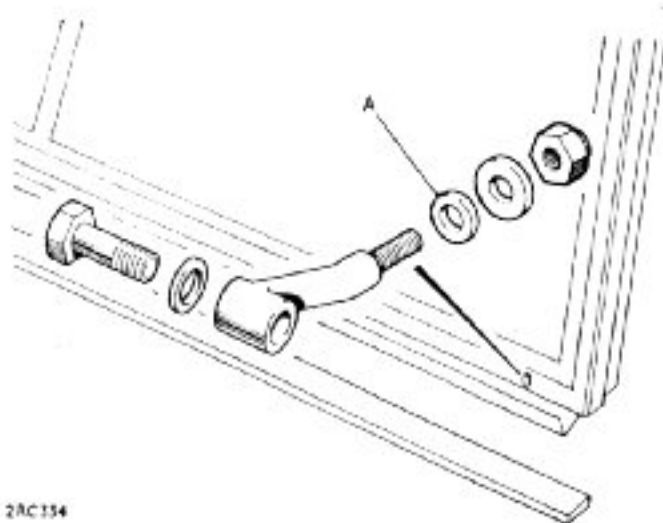

2AC154

Fig. 3 Windscreen pivot arm fixings

A—Copper washer

Item 42ASUBJECT: **PARKING LIGHTS (UK only)**

MODELS: All Land-Rover.

REMARKS: The lighting (standing vehicles) exemption regulations for the UK exempt passenger vehicles carrying up to 8 people and goods vehicles up to 30 cwt unladen from showing parking lights when parked in 30 mph zones. This exemption applies to all Land-Rover 88 wheel base versions but 109 models exceed both weight limits and carrying capacity and therefore must show two red and two white lights when parking.

Item 43**SUBJECT: AUXILIARY BATTERY CHARGING CONVERSION KIT****MODELS:** Land-Rover Series III, 88 and 109.**MODIFICATION:** Fitting of 18 ACR battery sensed alternator in conjunction with auxiliary battery charging conversion kit, split charge.**LITERATURE AFFECTED:** Fitting instruction, Part No. 607614, issue 1, May, 1972 refers.

PART NUMBERS:

Auxiliary battery charging conversion kit	1	607611	88 basic and Station Wagon 2½ litre petrol
Auxiliary battery charging conversion kit	1	607612	109 basic 2½ and 2.6 litre petrol 2½ litre diesel
Auxiliary battery charging conversion kit	1	608009	109 basic 2½ litre diesel 109 Station Wagon 2½ and 2.6 litre petrol
Auxiliary battery charging conversion kit	1	608010	109 Station Wagon 2½ litre diesel

REMARKS: It is essential to use an 18 ACR battery sensed single charge alternator with the above conversion set in place of the standard type.
The part numbers of the appropriate alternator and harness assemblies are as follows:

Alternator and harness conversion kit ..	1	607608	2½ litre petrol
Alternator and harness conversion kit ..	1	607609	2.6 litre petrol
Alternator and harness conversion kit ..	1	607610	2½ litre diesel

NOTE: Some vehicles are already fitted with an 18 ACR battery sensed single charge alternator as optional equipment. However, the majority of Land-Rover models are supplied with the 16 ACR alternator as original equipment, which is unsuitable for use with the auxiliary battery charging conversion kit.



Rover
British Leyland UK Limited
Sohull, Warwickshire, England

January, 1973

The headings in this index are in the same sequence as the divisions in the Repair Operation Manual. Under these headings each item is detailed alphabetically with the appropriate manual section or division number for easy reference. The last two columns indicate numerically, the individual items covered and the issue in which they appeared.

INDEX Vol. 1 Nos. 10 and 11

Description	Manual Section or Division	Model	Issue No.	Item No.
ENGINE				
Engines	A2 12	Series IIA Series III	11 11	44 44
COOLING SYSTEM				
Cooling system	26	Series III	10	39
MANIFOLD AND EXHAUST SYSTEM				
Inlet manifold	30	Series III diesel with servo-assisted brakes	10	40
FRONT SUSPENSION				
Distance piece for inner hub bearing	F 60	Series IIA Series III	10 10	41 41
REAR SUSPENSION				
Distance piece for inner hub bearing	E 64	Series IIA Series III	10 10	41 41
BODY				
Windscreen pivot arm	76	Series III	10	42
ELECTRICAL				
Parking lights	N 86	Series IIA Series III	10 10	42A 42A
OPTIONAL EQUIPMENT				
Auxiliary battery charging conversion kit	90	Series III 88 in. and 109 in.	10	43
Oil pressure gauge kit	90	Series III 2½ litre	11	45
SERVICE TOOLS				
Service tool adaptor kit	2	All	11	46
Service tool for gearbox mainshaft nut	2	All	11	47
MISCELLANEOUS				
E C A procedure (UK)	—	All	10	38A

* Item contains suffix letter change.

Policy items printed in bold type.

Item 44**SUBJECT:****ENGINES****MODELS:**

Land-Rover 2½ diesel, series IIA and III.

MODIFICATION:

Land-Rover 2½ diesel engines are now supplied less a number of ancillary items to enable a common replacement engine to be used for Series IIA from suffix K onwards and all Series III models.

PCMI**TRANSPARENCY:**

The information detailed in this item will be incorporated in the next available transparency.

LITERATURE**AFFECTED:**

Land-Rover Series IIA Parts Catalogue, Part No. 608024, page 02.66.

Land-Rover Series III Parts Catalogue Supplement, Part No. 608049, page 14.52.

PART NUMBERS:

Engine assembly, 2½ diesel—new	1	608227	} Series IIA from suffix K onwards. All Series III
Engine assembly, 2½ diesel—rebuilt	1	608228	

REMARKS:

The latest engines are less the following equipment:

Inlet manifold
 Exhaust manifold
 Starter motor
 Alternator/dynamo
 Fan belt
 Oil filter
 Oil pressure switch

This reduces the number of engines required for replacement purposes from five to one.

Provided the ancillary equipment is changed from the original to the replacement engine the latest engine can be used in lieu of the part numbers shown below:

Engine replaces	New	Re-built
Series IIA diesel	605654	605655
Series IIA diesel, 'Prestolite' alternator	605727	605728
Series IIA diesel, 'Lucas' IAC alternator	606082	606985
Series III diesel	607310	607311

Item 45**SUBJECT:****OIL PRESSURE GAUGE KIT****MODELS:**

Land-Rover series III 2½ litre petrol and diesel.

PART NUMBERS:

Oil pressure gauge kit assembly 1 607700

IDENTIFICATION:

Correct oil pressure gauge (Smiths BP 2208/01, 12 volt rating) 1 589137

REMARKS:

It has come to our notice that a small number of the above kits has been supplied with an incorrect oil pressure gauge, Part No. 545049 (Smiths PE 2300/00) which is not compatible with the transmitter.

This results in less than half of the correct oil pressure being indicated by the instrument.

In the circumstances, Distributors and Dealers are asked to check any stock they may have of the above kit and exchange, through the Parts Department at Cardiff, any incorrect gauges for the specified type, Part No. 589137. If a gauge has already been used and found incorrect a new one should be ordered from the Parts Department at Cardiff, the used gauge being returned to Solihull under normal Warranty Claim procedure.

NOTE: The re-printed version of Fitting Instructions No. 607701, Issue 2, August, 1972 showing revised transmitter fitting and oil pressure gauge wiring connection should be used with these kits. This also applies to kit 607702 for 2.6 litre petrol models. Copies of this fitting instruction are obtainable from the Technical Service Department at Solihull.

Item 46**SUBJECT: SERVICE TOOL ADAPTOR KIT**

MODIFICATION: Introduction of an adaptor kit to suit impulse tool 18G284, to aid commonisation. The kit also provides all the adaptors previously included with impulse tool 530101.

MODELS: All Land-Rover.

LITERATURE AFFECTED:

Land-Rover Series II and IIA Workshop Manual, Part 1, English, Part No. 606407, Sections A1, A2, and A3.

Land-Rover Series II and IIA Workshop Manual, Part 2, English, Part No. 606408, Section Z.

Land-Rover Series III Repair Operation Manual, English, Part No. 607314, Divisions 12 and 99.

PART NUMBER: Impulse tool kit and adaptors 1 530101A

REMARKS: When stocks of the earlier impulse tool and adaptor kit 530101 are exhausted only the above listed tool kit 530101A will be stocked. The kit is for use with the current impulse tool 18G284 which, if not held, must be ordered separately.

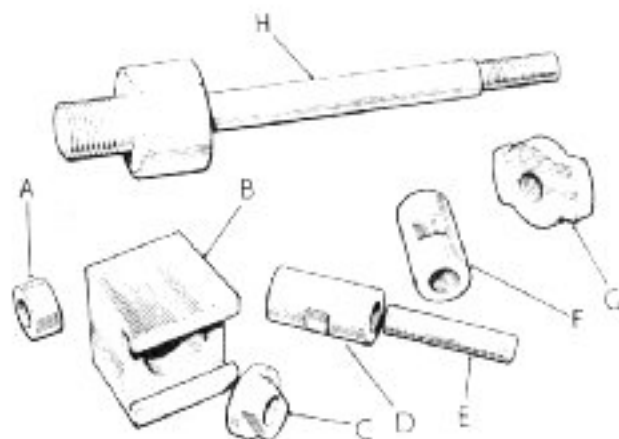

2RC 541

Fig. 1 Impulse tool kit 530101A

- A—Adaptor for small gudgeon pin
- B—Shaft extractor claw
- C—Adaptor for large gudgeon pin
- D—Adaptor for big-end bolts
- E—Adaptor for camshaft removal
- F—Adaptor for big-end bearings
- G—Tappet extractor
- H—Adaptor to fit impulse tool 18G284

Distributors and Dealers are requested to mark up their Series II and IIA Service Literature in accordance with the above information. The Series III Repair Operation Manual will be revised accordingly at the next available revision.

Service Tools are supplied by:

V. L. Churchill & Co. Ltd.,
P.O. Box No. 3,
London Road,
Daventry,
NORTHANTS,
NN11 4NF.

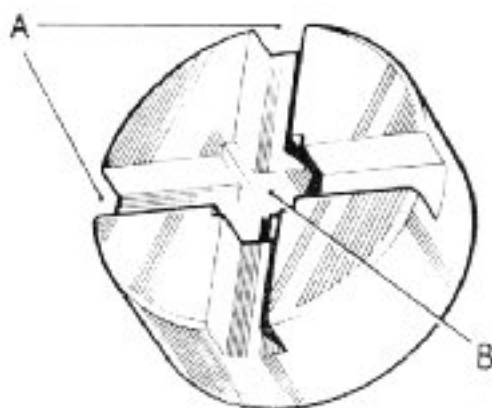
Item 47**SUBJECT: SERVICE TOOL FOR GEARBOX MAINSHAFT NUT****MODELS:** All Land-Rover.**MODIFICATION:** Introduction of a torque spanner adaptor for use with the existing box spanner, Part No. 600300, for the gearbox mainshaft nut.**LITERATURE AFFECTED:** Land-Rover Series II and IIA Workshop Manual, English, Part No. 606407, Operation C1-22.
Land-Rover Series III Repair Operation Manual, English, Part No. 607314, Operation 37.20.25.**PART NUMBER:** Torque spanner adaptor for mainshaft nut spanner 1 RO 1013**REMARKS:** The current gearbox build specification requires the special nut Part No. 217477 at the transfer gear end of the gearbox mainshaft to be tightened to 12,5 kgf.m (90 lbf.ft.) prior to turning up the lockwasher. The above listed adaptor is now available for this purpose and is designed to fit on the end of the existing mainshaft nut spanner Part No. 600300. It is recommended that this torque loading be applied on earlier, as well as later, gearboxes during the applicable overhaul procedure.

2RC 322

Fig. 2 Torque spanner adaptor RO 1013 for mainshaft nut spanner

A—Castellations to fit spanner 600300

B—12,7 mm (0,500 in.) square for torque spanner